

## An Introduction to the SolarGiant III



The completely re-designed SolarGiant, designated the SolarGiant III was introduced to the market at the Solar Power 2008 Conference in San Diego on October 14, 2008. The SolarGiant III is now available for order from the Conergy catalog. This document provides introductory design and application information for this attractive new Mounting Systems product.

### **What is the SolarGiant?**

The SolarGiant is a fixed-tilt, ground-mounted PV array structure. It is essentially a ballasted array that, in its basic form, is attached to two concrete footers sized to anchor the array against any wind uplift. Because the footers can simply rest on the site surface, the SolarGiant is an ideal mounting system for difficult site conditions such as rocky soils, high water tables, membrane-capped landfills and more. The SolarGiant's simple but rugged and durable design, coupled with extensive pre-assembly makes it exceptionally easy and fast to assemble and erect.

While the SolarGiant can be configured to hold frameless modules such as First Solar laminates, it is intended primarily for framed modules. One of the SolarGiant's key features is its slide-in rail module mounting system shown below in Figure 1.

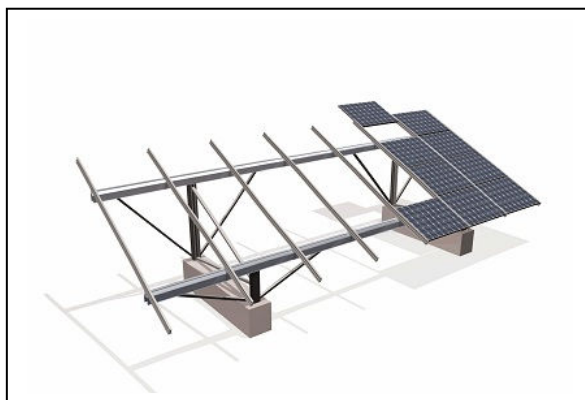

**Figure 1. SolarGiant Slide-in Rail Module Installation**

As can be seen, there are no individual clamps that must be installed and tightened to secure the modules. The modules simply slide into rails and are held in place by a stop bolt at the top and bottom of the rail. This provides two important advantages. First, module installation is very fast and easy and second, the modules are supported along their entire length which minimizes any possibility that the module can flex or deform.

A second important feature of the SolarGiant III is the speed and ease with which it can be assembled and erected on the footers. Starting with the mounting feet in place on the ballast footers, a two man crew, working at a relaxed pace, can assemble and erect a 4800W (200W modules) SolarGiant structure in about 45 minutes. Footplate location and installation takes approximately 20-25 minutes and module installation about 15 minutes. This means that a typical 20-man construction crew can assemble, erect and install modules at the rate of about 1.9MW *per week*.

### **Key Components of the SolarGiant III?**

The SolarGiant III is a completely redesigned version of the highly successful SolarGiant II which has been installed in large quantities across Europe. Because design wind speeds in Europe are generally lower than in North America, the SolarGiant II was only marginally adequate for typical North American wind and snow loads. The SolarGiant III has been designed from the outset with North American requirements in mind. Equally important, the new SolarGiant III has been designed to take advantage of standard structural shapes to minimize costs.

Key components of the SolarGiant III include:

- A highly engineered main cross beam (see Figure 2)
- Uniform profile legs and diagonal braces
- Slide in rails redesigned for faster, easier assembly
- Extensive component pre-assembly for exceptionally fast structure assembly and module installation
- Standard 15° - 35° tilt angle range in 5° increments.

Main Cross Beam

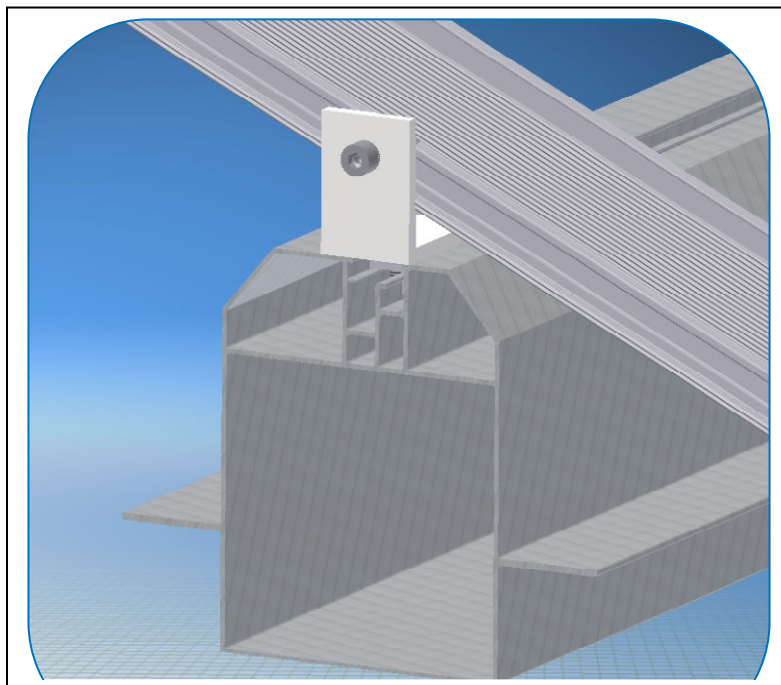

**Figure 2. SolarGiant III Main Crossbeam**

The SolarGiant III main crossbeam is the main structural support for the array field. The new design is a highly efficient, fully boxed structural member that optimizes structural strength and material usage. The design incorporates a Quickstone® channel at the top of the beam that simplifies and speeds installation of the SolarGiant's unique slide-in rails.

The crossbeams are supplied standard as a single unit at the maximum 8.25m / 27' span or, if required or desired, at 4.1m / 13.5' lengths that can be connected on-site with the SolarGiant III beam splice (Figure 3). The SolarGiant III splice is also a fully boxed structural element and is completely enclosed in the crossbeam box section.

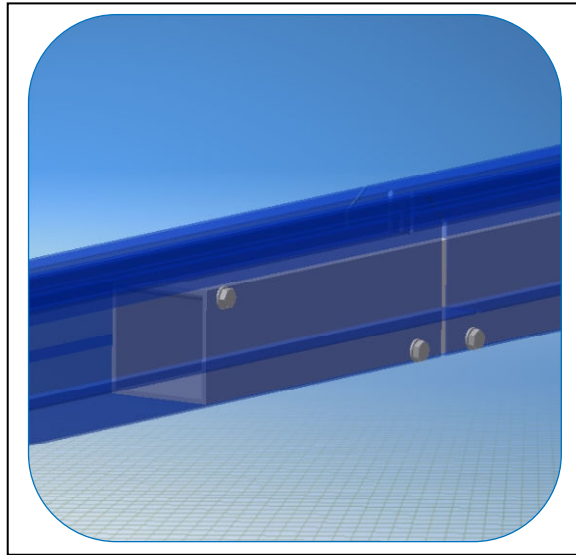

**Figure 3. SolarGiant III Crossbeam Splice**

#### Leg and Diagonal Brace Connector

The SolarGiant III uses a simple, high-strength extrusion to connect the diagonal bracing to the structure legs and crossbeams. This proprietary connector (Figure 4) minimizes the SolarGiant parts count and contributes to the SolarGiant's fast and easy assembly. SolarGiant rear legs are supplied with the Leg and Diagonal Brace Connector pre-assembled. All mounting holes on the SolarGiant III are pre-drilled and all necessary hardware and parts are included with the SolarGiant III to speed assembly and eliminate the need to do any drilling, cutting or fabrication in the field.

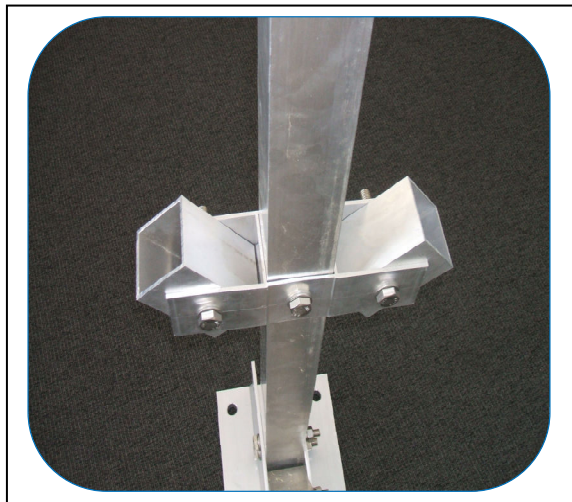

**Figure 4. SolarGiant III Diagonal Brace Connector**

## Mounting Foot

The SolarGiant III mounting foot, shown in Figure 5, is also pre-drilled for all upper structure bolts and connections and for the anchor bolts that hold the structure to the concrete footer. Even the anchor bolts are included standard with the SolarGiant III.

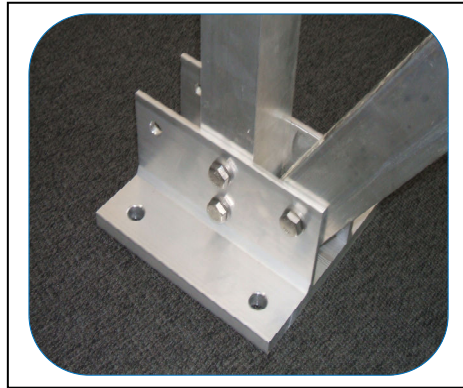

**Figure 5. SolarGiant III Mounting Foot**

## SolarGiant III Advantages

On a total cost basis, the SolarGiant enjoys five significant advantages over other ground mounting systems: 1) initial design and procurement, 2) fabrication, 3) assembly, 4) structure anchoring and 5) module installation.

### Initial design and procurement

The SolarGiant III is supplied as a complete, kitted system, ready to assemble. No time-consuming design or calculation of component lengths or quantities is required. The SolarGiant III, in its standard configuration will hold 24 Canadian Solar, Day4 or Conergy PowerPlus modules in a 3H x 8W configuration and 27 Sanyo HIT or N modules in a 3H x 9W configuration.

Some designs are intended to be constructed of locally procured iron pipe. The expectation is that customers must themselves find, qualify and obtain competitive pricing from vendors in the vicinity of the project site. Further, it is also necessary in these cases for the customer or installer to either cut the pipe to the various lengths required or to locate and qualify vendors to do that work as well.

The SolarGiant, on the other hand, is supplied as a completely engineered solution requiring no design, vendor qualification or other up-front investment of time or effort.

### Fabrication

The SolarGiant III requires no field fabrication, drilling or cutting. It is supplied as a complete, ready-to-assemble kit with all necessary parts and hardware, with all holes pre-drilled and all parts cut to the proper length. Parts are pre-assembled as much as possible while still allowing the product to be shipped. Other designs use a more complex structure and require the locally procured materials used to build the array be cut to length and, for some components, threaded. With no cut-to-length or pre-fabricated components, the installer must do the cutting himself or have it done by local suppliers or fabricators. The cost for these procedures can be quite substantial in terms of both time and direct expense.

No on-site, or for that matter, off-site fabrication by customers or installers is required for the SolarGiant III. The SolarGiant III structure arrives as a complete kit and needs only to be assembled on site with standard hand-tools.

## Assembly

SolarGiant III comes to the site ready to assemble. All the items necessary to complete the structure are supplied, down to the stainless steel bolts, washers and nuts as well as the anchors that hold the mounting plates to the concrete footers. All holes are pre-drilled and parts cut to standard lengths. And, as noted earlier, the SolarGiant arrives extensively pre-assembled to further reduce the assembly time. Think IKEA. Many parts require only sliding into position and tightening bolts that are already in place. Slide-in rail supports, for example, come pre-assembled with special Quickstones and need only to be dropped into position along the main beams and tightened. Centerline scribe marks on the Crossbeams aid in quickly locating and installing the supports. SolarGiant III provides unmatched assembly ease, speed and efficiency. Other pre-assembled items also contribute to the SolarGiant's unprecedented assembly ease and speed.

## Structure Anchoring

The SolarGiant III is essentially, a ballasted system in that it does not rely on friction between a caisson or piling and the soil for anchoring. The two footers on which the SolarGiant rests are sized to provide the weight needed to resist wind-induced uplift. This gives the SolarGiant III several advantages over other systems that are designed to be mounted in the ground or to caissons, pilings or other devices in the ground. These advantages are summarized in Table 1, below.

**Table 1. SolarGiant III Anchoring Advantages and Benefits**

<b>Footer Feature</b>	<b>Advantage</b>	<b>Benefit</b>
Surface mounting	No excavation	Reduced project cost
		Reduced project completion time
		Easily accommodates difficult soil conditions (rocks, sand, etc.)
		No soil penetration (landfills, tundra, sensitive environments)
		Ideal for high water table sites
		Reduced project cost
		Shorter project completion times
Individual blocks	Can be pre-cast	Reduced environmental impacts
		Simplifies large project logistics
		Local concrete companies can make custom pre-casts
		Reduced per anchor cost
		Reduced project labor costs
		Economical for smaller projects
		Can be cast on-site
Variable form factor	Can be cast on-site	Can be shaped to accommodate particular site conditions
		Array height can be varied with footer dimensions to accommodate site requirements
		Speeds footer installation
Non-critical location	SolarGiant structure attaches to anchors installed in footers <i>after</i> footer is in place	Speeds structure erection
		Reduced labor costs

It is, of course, possible to mount the SolarGiant III on caissons or other supports such as ground screws or even pilings driven into the ground if, for some reason, that is desirable for a particular project. In these cases it is mandatory, as with any other similarly mounted system, that a qualified soils engineer be consulted to calculate and sign off on support type suitability as well as parameters such as support dimensions and depths.

In short, though, the SolarGiant III provides many advantages over other ground mount systems including overall project cost, project construction time, labor efficiencies, site versatility, site utilization, environmental impact and mounting flexibility and adaptability to a wide range of site types and conditions.

#### Module Installation

As though initial design and procurement, fabrication, assembly and structure anchoring did not provide enough competitive advantage, there is another, perhaps even more important competitive advantage – the SolarGiant's slide-in rail module mounting system. The SolarGiant III's unique slide-in rails allow the PV modules to simply slide into place, one after another, into a continuous channel. This is shown in Figure 6 below.

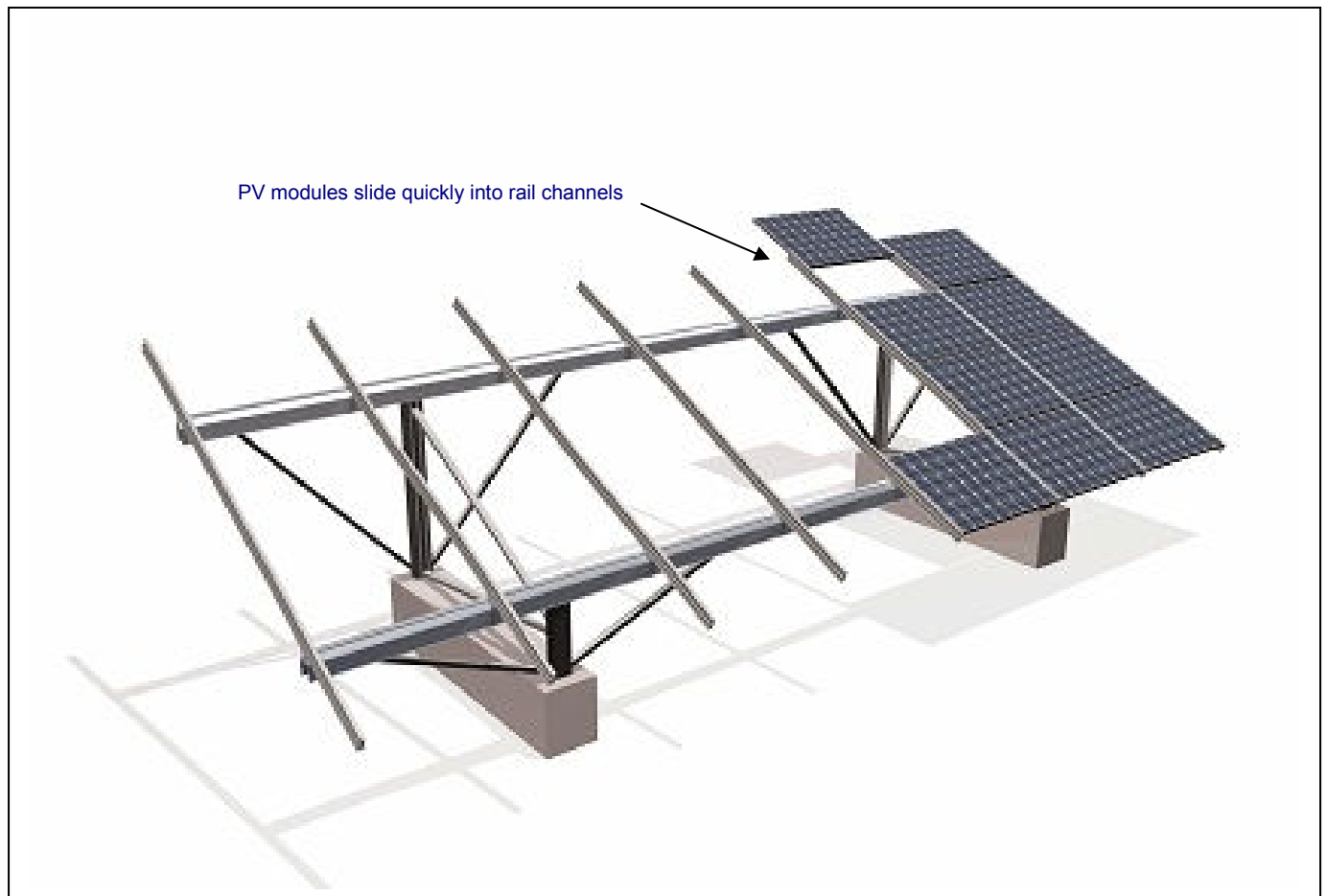

**Figure 6. SolarGiant Slide-In Module Mounting**

The slide-in rails incorporate features that provide a number of useful advantages to SolarGiant customers. The first of these advantages is, of course, the speed with which the modules can be installed in the array. The modules are simply lifted to the channel and slid down to abut the end stop or the previously installed module and the process is repeated until the column is filled and the array is complete. Stop bolts at the lower end of the channel hold the first module and an additional bolt at the top of the channel locks the modules in place and prevents unauthorized removal. No additional time-consuming individual clamping is required to hold the modules in place.

A second advantage is that the slide-in rails support the modules along their entire length thereby maximizing their ability to withstand wind and snow loads.

The rails include a rain channel to drain rain, snow melt and condensation out of the array.

The rail itself is designed to provide strength and rigidity to the SolarGiant structure and the module array and facilitates the SolarGiant's ability to accommodate 20psf / 0.96 kN/m<sup>2</sup> snow loads at 15° tilt and the 90mph / 40m/s wind loads at 30°. Figure 7 shows a cross section of the SolarGiant slide-in rail.

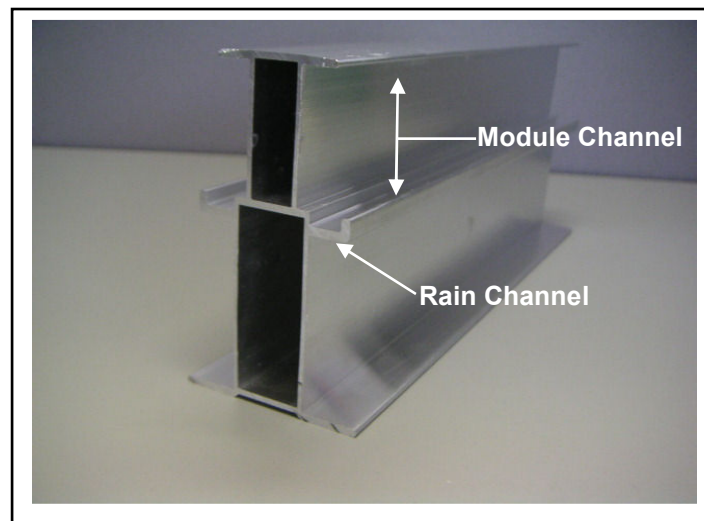

**Figure 7. SolarGiant Slide In Rail**

Generally speaking, PV modules will be mounted in portrait mode in the slide-in rails so that the modules are supported along their length. This is where the manufacturer-recommended mounting points are usually located. Modules may be mounted in landscape and supported on their short sides *if short side mounting is approved by the module manufacturer*. If the module manufacturer does not approve of short side mounting, installing the modules in this mode may void the module warranty. If it is necessary for site restriction, shading or other reasons to mount modules on the SolarGiant in landscape mode, special, heavy-duty versions of the SunTop rail, special rail mounting hardware and standard SunTop module mounting clamps are available to allow landscape mounting. This is, naturally, a somewhat more time-intensive proposition but given the many advantages of the SolarGiant III, is still be a viable and economical solution.

The SolarGiant III is designed to provide maximum competitive advantage as a mounting system for framed modules. It can, though, accommodate laminate modules such as the First Solar thin-film laminates. This is accomplished by installing the same modified, heavy-duty version of the SunTop rail described above and mounting the laminate modules using special laminate module clamps available from Conergy and specifically approved by First Solar.

### **Electriwedge<sup>®</sup> option**

The SolarGiant's competitive speed and convenience advantages don't stop with only assembly and module installation. Module and structure grounding requirements have also been taken into consideration in the design of the SolarGiant III. Working in close cooperation with Wiley Electronics, Conergy has developed a unique and proprietary grounding scheme for the SolarGiant called, *Electriwedge*.

Electriwedge is an optional accessory for the SolarGiant III consisting of a combination of wedge-shaped pieces that fit in the SolarGiant slide-in rail channels below the modules, specially designed WEEB clips and channel end stops. An example of the wedge piece is shown below in Figure 8. Figure 9, below, shows WEEB clips. The WEEB clips are inserted between the top of the module frame and the slide-in rail channel. The wedges are then put in

place below the module and tapped into place. Conergy recommends the wedges be tapped into place with a hard rubber or other non-metallic hammer or mallet. A piece of wood may also be used with a standard hammer to tap the wedges into place. Tapping the wedge into place causes teeth in the WEEB clips to make firm electrical contact between the module frame and the rail. When installation is complete, the entire module array is electrically bonded and a single lug can be used to connect the array to ground.

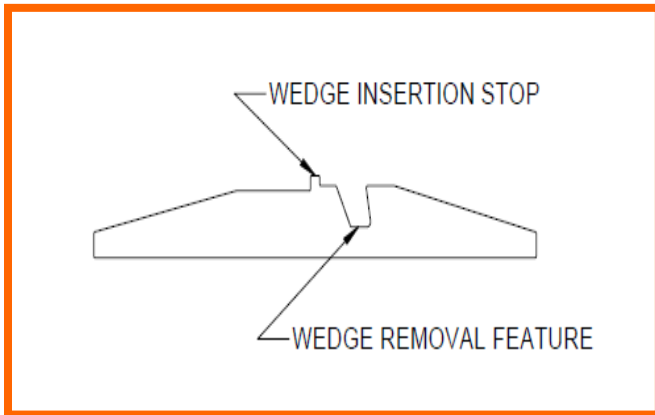

Figure 8. SolarGiant Electriwedge



Figure 9. SolarGiant WEEB clips

Figure 10, below, shows details of the Electriwedge system installation.

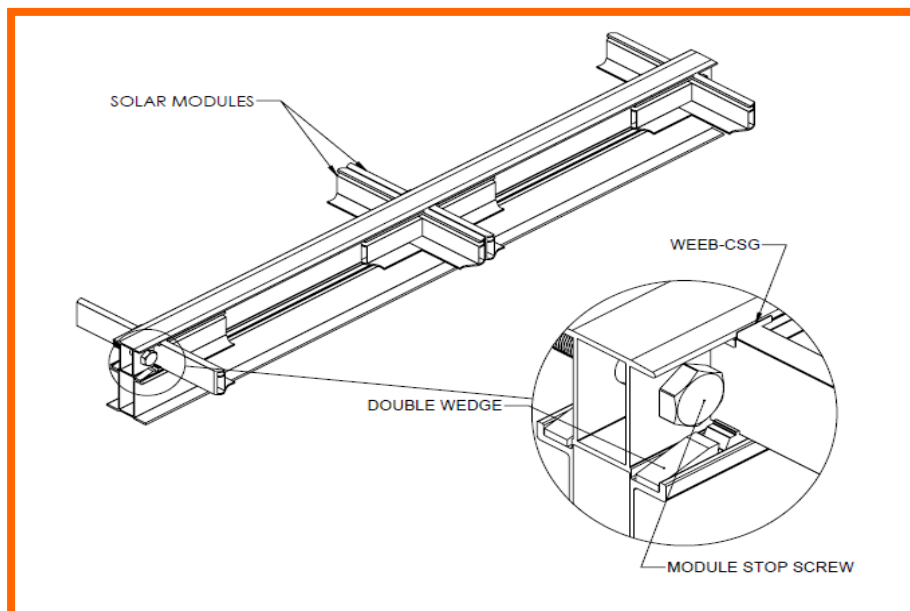

Figure 10. SolarGiant III *Electriwedge* system detail

### SolarGiant III Configuration and Ordering

To make ordering simple, easy and reliable, the SolarGiant III has a number of discrete configurations for the most popular module frame thicknesses. The only difference between the various versions of the SolarGiant is the slide-in rail module thickness and the length of the rear legs. Simply select the SolarGiant model number with the slide-in rails you need, the tilt angle your project requires and the wind loading capability (90 or 120mph).

You will need to know the thickness of the modules to be used with your SolarGiant so you can select the model with the correct slide-in rail channels. SolarGiant slide-in rails are available for

modules of 35mm, 40mm, 46mm and 50mm thicknesses. Thus, the SolarGiant III can accommodate modules from Suntech Power, Day4 Energy, Canadian Solar, Sanyo, Sharp, Conergy, BP and others. Table 2, below, shows the most popular modules for which slide-in rails are available. Additional slide-in rail thicknesses will be added as volumes warrant.

**Table 2. Module thicknesses for selected PV modules.**

<b>Rail Channel</b>	<b>35mm</b>	<b>40mm</b>	<b>46mm</b>	<b>50mm</b>
BP SX-J				■
Canadian Solar CS6P		■		
Conergy PowerPlus			■	
Day4 48MC	■			
Sanyo BA19 or N			■	
Sharp SESG			■	
Schott SAPC			■	
Suntech STP	■			

The maximum number of modules that can be carried by an individual SolarGiant structure varies by module type (but not by much). For most modules, the SolarGiant will hold 24 modules in a 3-high by 8-wide matrix. The exceptions to this are Sanyo BA19 modules which, because of their aspect ratio, can be loaded 3-high by 9-wide for a 27 module array and First Solar laminate modules. The maximum module complement is primarily a function of the wind loading that the SolarGiant is certified to withstand – about which, more, shortly.

First Solar and other, similarly sized laminate modules cannot, at this time, utilize slide-in channels. The module manufacturer has not approved this mounting method. For these modules, the SolarGiant III can be configured with a special, high-strength version of SunTop rail instead of slide-in channels. The laminate modules are then mounted to these rails with standard top clamps certified by First Solar as being approved for use with their modules. This version of the SGIII can hold 42 First Solar modules in a 7-high by 6-wide landscape configuration.

### **Structural Engineering Certificate**

*The SolarGiant III is PE certified.* Every model in the catalog can be provided with a stamped letter from a licensed, professional engineer certifying that the SolarGiant III meets all the standards and requirements of the International Building Code (IBC) 2006, the "2000 Aluminum Design Manual" and the American Society of Civil Engineers (ASCE) ASCE 7-05. This certification applies to the SGIII structure and is valid for each of the models in the catalog for wind loading up to 90mph and ground snow loads up to 20 psf for any tilt angle of 30° or less. This certification is not specific to a local jurisdiction. However, if a local certification is required, this letter should significantly speed and simplify the process and substantially reduce the cost of obtaining a local stamp. Conergy can also supply the structural analysis data to a local engineer, further reducing the time and costs required for a local stamp. It is possible that a local stamp may be required for local footer design. Although Conergy can make certain recommendations and suggestions, responsibility for this process and cost must be borne by the customer.

Fully certified SolarGiant versions capable of 120mph wind loading and the same snow and tilt angles as above are also available.

Custom SolarGiant designs for configurations and/or capabilities outside these standard parameters can be accommodated upon special order.

It is important to note that the main purpose of the SolarGiant's concrete footers is to support the structure's weight and loading and provide ballast against uplift. Conergy can not determine the suitability of the site's soil conditions, stability or suitability for the installation of the

SolarGiant. Conergy can supply, upon request, the point load data for the SolarGiant at each leg. Conergy strongly recommends that an independent soils engineering report be conducted to verify that the site is suitable for the SolarGiant's configuration and load. Note, though, that any footer form-factor which can support the specified mounting point load *and* provide the required uplift ballast may be used. Thus, the footer's shape itself can be designed to accommodate the site and soil conditions. This is a significant advantage of the SolarGiant III over other open field array mounting systems.

### **SolarGiant Pricing**

SolarGiant III pricing is also exceptionally competitive. It is even more competitive when the labor costs of structure assembly and module installation are included. The SolarGiant can dramatically reduce your overall project timetables and project costs. Consider the estimate noted earlier that construction and assembly of the SolarGiant III structure will take two people approximately one hour. As noted there, it is eminently feasible for a 20-man construction crew to assemble structures and install modules at a rate of about 1.9MW *per week*.

### **SolarGiant Summary**

The Conergy SolarGiant III is a highly significant new entry in the PV market. The combination of low upfront material cost, exceptionally fast structure assembly and module installation coupled with its ability to handle a wide variety of site and soil conditions and its simple footer foundations make the SolarGiant the new standard for moderate to large-scale ground mounted PV arrays.